

V-8 MAGNUM

Intake Manifold Plenum Cover Reinforcement Plate Installation Instructions

Note: None of the factory hold down bolts will be reused.

Step 1: Remove the intake manifold and lower plenum cover. Clean all sealing surfaces by hand. Do not use any power driven tools (scotch-brite etc...)

Step 2: Make sure all of threaded holes are clean and deep enough to accept bolts.

Step 3: Install the new plenum cover gasket. (Do not use any type of gasket sealer)

Step 4: Locate and position the new plate on the intake manifold.

Step 5: Install the plate using the supplied 1/4" x 3/4" bolts and 1/4" washers.

Note: We suggest using blue thread lock on the bolts.

Step 7: Tighten the bolts in the sequence shown in the diagram. Tighten them in this pattern three times, each time tightening them to the next specified torque.

Step1----48 inch pounds (That's not foot pounds Bubba!)

Step2----84 inch pounds

Step3----84 inch pounds again

Step 7: Re-install the manifold as per factory specifications.

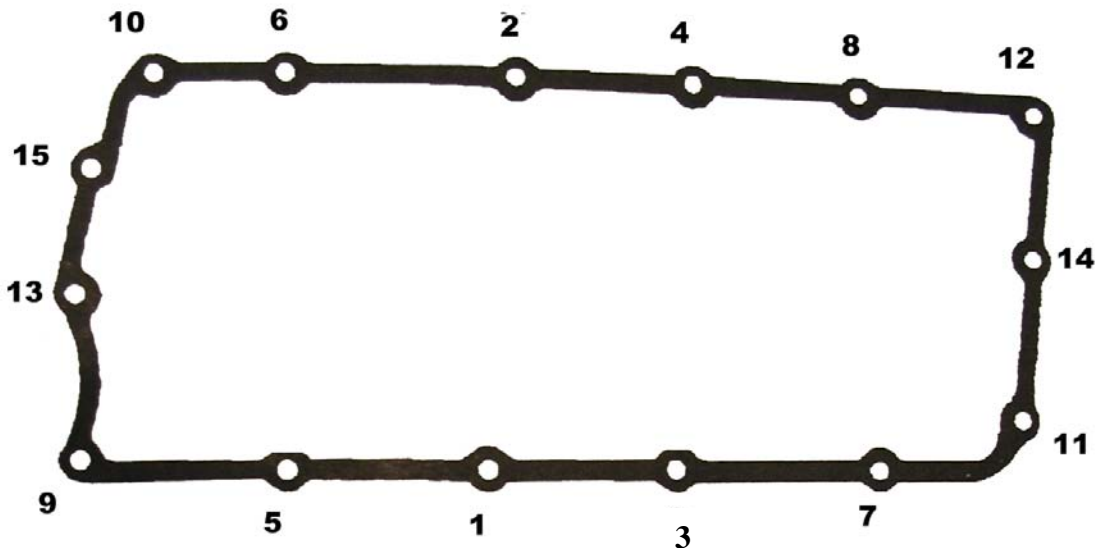

Intake Removal & Installation V8 Dodge Magnum

1. Disconnect the negative battery cable from the battery.
2. Drain the cooling system
3. Remove the A/C Compressor
4. Remove the alternator
5. Remove the accessory drive bracket
6. Remove the air cleaner
7. Perform the fuel pressure release procedure (Refer to service manual)
8. Disconnect the accelerator linkage and if so equipped, the speed control and transmission kick down cables.
9. Remove the return spring.
10. Remove the distributor cap and wires.
11. Disconnect the coil wires.
12. Disconnect the heat indicator sending unit wire.
13. Disconnect the heater hoses and bypass hose.
14. Remove the closed crankcase ventilation and evaporation control system.
15. Remove intake manifold bolts.
16. Lift the intake manifold and throttle body out of the engine compartment as an assembly.

To replace the plenum plate and gasket refer to the Hughes Engines instructions provided with the plenum repair kit.

To install the intake manifold

1. Install gaskets in proper positions. You may need some silicone at the corners of the intake.
2. Lay the intake and throttle body assembly back onto the engine.
3. Follow these steps for intake bolt installation.

5.2L / 5.9L Intake Manifold Flange Bolt Torque Procedure

STEP	WHICH BOLT	TORQUE
1	1 through 4	1.4 Nm (12 in. lbs.)
2	1 through 4	2.7 Nm (24 in. lbs.)
3	1 through 4	4.1 Nm (36 in. lbs.)
4	1 through 4	5.4 Nm (48 in. lbs.)
5	1 through 4	6.7 Nm (60 in. lbs.)
6	1 through 4	8.1 Nm (72 in. lbs.)
7	5 through 12	8.1 Nm (72 in. lbs.)
8	Check All Bolts	8.1 Nm (72 in. lbs.)
9	All Bolts	16.3 Nm (12 ft. lbs.)
10	Check All Bolts	16.3 Nm (12 ft. lbs.)

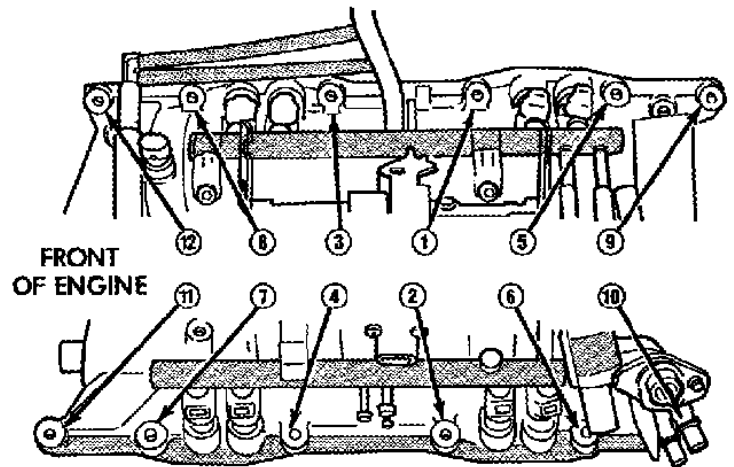

**5.2L / 5.9L Intake Manifold
Bolt Tightening Sequence**

FIGURE 6