

THANK YOU FOR PURCHASING OUR ROCKERS

We have designed and engineered these “Real” Chrysler rockers specifically for MOPAR wedge engines (not something modified to be “close enough” to work on a MOPAR). The finish on them is different from what you may be accustomed to and definitely not for the ‘tuner transformation’ crowd. They are not ‘glitzy’ or as pretty as the ones you owned before, but they are better! Our goal was to design a very high quality, accurate, and strong rocker with Nascar® and pro-stock type features within a tight price limit (with beauty as our last concern).

The most obvious difference in our rockers is the dramatic new design. This change is more than just visual, it is functional as well. By opening the area above the roller, it is now exposed to the flood of oil coming from the underside of the valve covers. This helps provide lubrication to the axle and roller along with lightening the valve end of the rocker where weight loss is the most critical.

We re-located the roller tip and pushrod cup positions, improving the geometry – and, we changed the oil system. These are fully CNC machined and extremely accurate. They’re not built in drill fixtures like most other so-called MOPAR rockers. The oil hole to the pushrod is re-positioned and smaller. The proper location requires less oil, leaving more for the shafts and rollers. The roller tip diameter is larger (stronger) and the pin axle is larger (stronger). The ratio is marked on the rocker to eliminate confusion. The shaft bore is not honed; honing is not as accurate as boring.

Now, to the finish! The rocker is not anodized for appearance, for three reasons:

- 1) It is an additional cost, and
- 2) It is an additional operation; the anodized material must be honed out of the bores.
- 3) We do not believe an anodized bore surface is the best bearing surface.

Nascar® and Pro-stock rockers are not anodized. What works for them will work for us.

We are very happy with the accuracy and performance of these rockers and feel confident that with use you will agree they are a quality product. Thanks again for looking to Hughes Engines for your MOPAR performance parts.

P.S. Soak the roller tip end in oil before assembly!

ROCKER ARM SHAFTS

All shafts must be thoroughly cleaned before installing them in your engine. Failure to do so may result in premature engine failure.

Please note the revised oil system on these rocker shafts. The flat chamfer helps to spread the oil film on the lower side of the shaft and the lower side of the bore in the rocker. The pressure from the pushrods and valve springs are concentrated in this area so anything that encourages oil film is an improvement. Any questions please give us a call at 309-745-9558.

Rocker Shafts HUG1600 & HUG1620

Note the revised oil system on these new rocker shafts. The new flat chamfer helps to spread the oil film on the lower side of the shaft and the lower side of the bore in the rocker. The pressure from the pushrods and valve springs are concentrated in this area so anything that encourages oil film is an improvement. Any questions please give us a call at 309-745-9558.



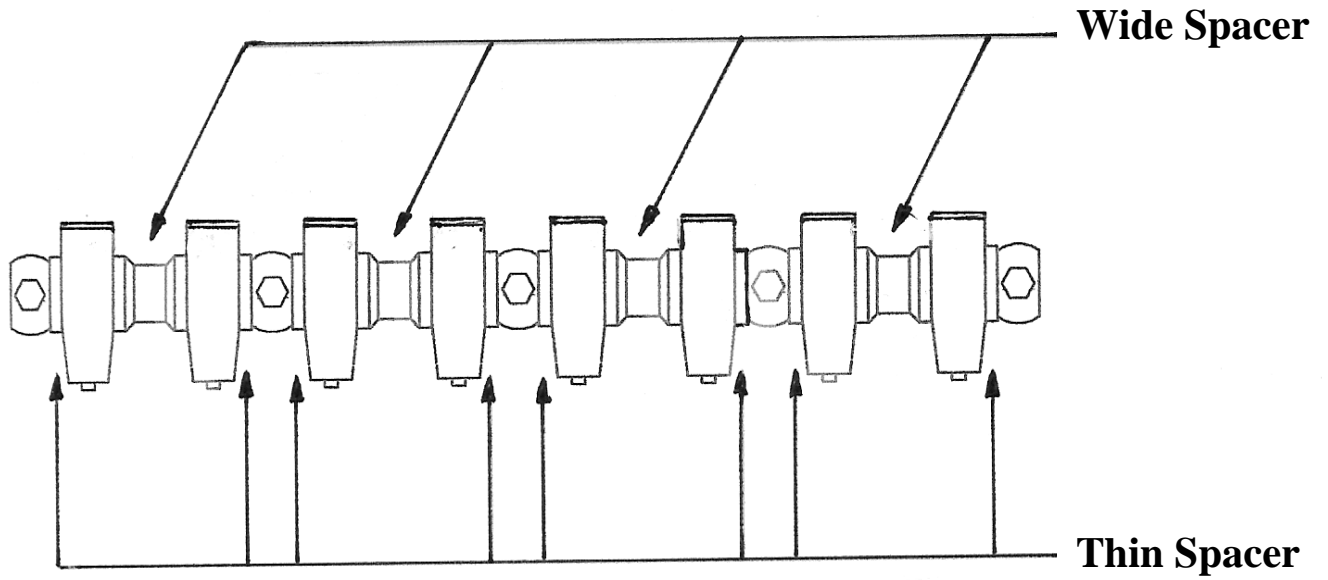

Small Block Chrysler ↑

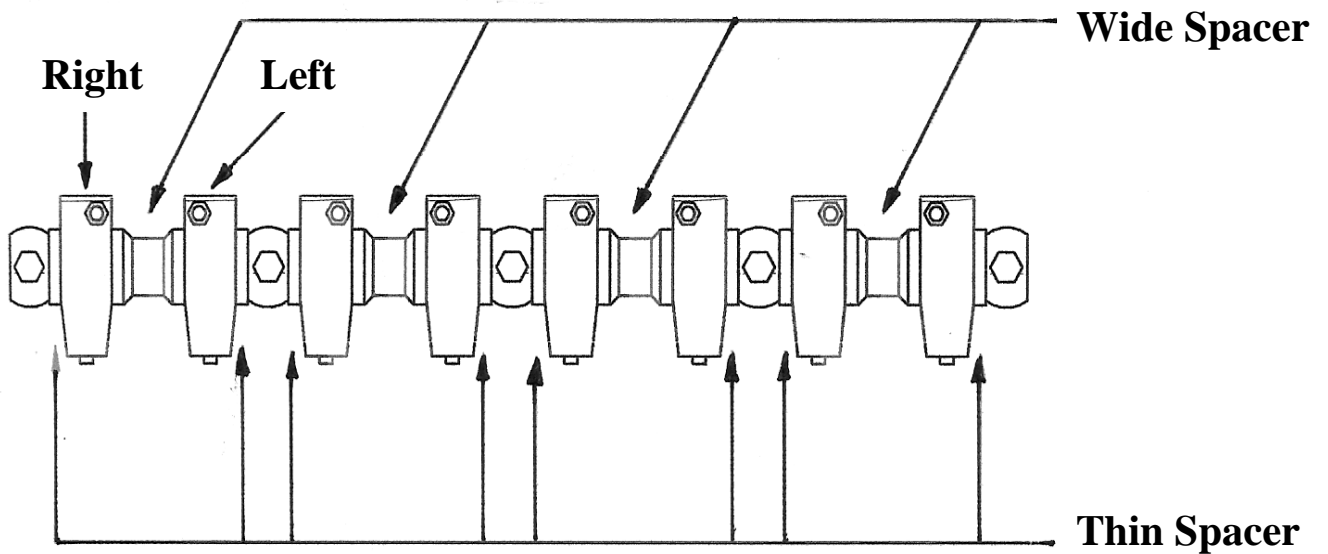

Big Block Chrysler ↑

ROCKER SADDLE SHIM INSTRUCTIONS

P/N's 1708 – 1709 – 1710

If you do not need to stack the shims no trimming is required, however, in some cases you may find that you need to stack these shims to achieve the proper rocker arm geometry and/or pushrod length. If this is the case, we recommend trimming the lengths of the shims to get them to “nest” together better, and prevent distortion of the shaft of pedestal.

Trim the shims as follows:

The bottom shim, trim to $.187'' \pm .010''$

The second shim, trim to $.130'' \pm .010''$

The third shim, trim to $.085'' \pm .010''$

When stacking, compress each shim separately before final tightening.



How to measure trimmed shim.



Layout of stacked shims.



If you have any questions, give us a call!
309-745-9558

ROCKER ARM ASSEMBLY INSTRUCTIONS

The following steps should be used to achieve maximum performance and life from your new rocker arms. Failure to do so may result in rocker arm failure and/or valve train damage.

1. Used rocker shafts are not recommended and generally they are out-of-round, galled, scored, or worn. For best results, use new ones, ours have banana grooves for better lubrication. Prior to installation of used rocker shafts, thoroughly clean the shafts especially the inner bore.
2. Using the attached diagram, assemble the rocker arms/shafts as shown. Be sure and use the enclosed high-pressure prelude (such as cam lube) on the rockers and shafts when assembling them. Install the shafts on the heads according to the diagrams in Illustration #1 and note the oil hole positions.

Torque: All Small Block shafts: 16 ft-lbs (with 30W oil on the threads)

All Big Block shafts: 30 ft-lbs (with 30W oil on the threads)

3. The rocker tip should be centered as close as possible left to right over the tip of the valve. We have included 0.015" and 0.030" shims to be inserted between the rockers, spacers or hold-downs for alignment of the tip (Illustration #2). Total side clearance between a pair of rockers should be 0.005"/0.015". In some cases the roller can be off center. (See illustration #3)
4. The positioning of the rockers is best accomplished by using our heavy-duty billet steel hold-downs, which can be custom fit for perfect alignment. (P/N: HUG 7440 for Small Blocks, HUG 7442 for Big Blocks).
5. Rocker arm positions on shafts are very critical, especially on Small Blocks where rocker/retainer clearance is close. The rocker to retainer/spring clearance is closest when the valve is closed. It should be a minimum of .020". Shims between the saddle and shaft may be needed to get this clearance. Our kit, P/N 1710, includes .020" and .040" shims and is included in our rocker arm kits.
6. Also check for pushrod to tunnel clearance on Small Blocks, some intake pushrods will drag in the tunnel. You need a minimum clearance of .010" at this point. Check with valve open and closed. Questions? Call us!
7. The rocker arm tip/roller should wipe across the center of the valve stem tip when the valve is lifted through its entire travel. This wipe pattern is most easily determined by "painting" the top of the valve stem with a felt tip marker and turning the engine over a few revolutions. This will leave a mark in the ink showing the wipe pattern (See Illustration #4). If you find the wipe pattern is not centered as shown or is very biased to the inner or outer edges of the valve stem, it must be corrected. If not corrected, premature stem and valve guide wear will result. Shims between the saddle and shaft will be needed in most cases to correct the geometry.
8. Hydraulic lifter preload (Illustration #5) is very important. The preload is determined by the intended use. See our hydraulic lifter instruction sheet for details. The best way to check for proper hydraulic lifter preload and pushrod length is to use our exclusive adjustable checking lifter (P/N 8100). When setting up the pushrod length and rocker geometry, the rocker arm adjusting screw threads should never go below the top of the locknut. If they do, there will not be enough threads for proper locking.
9. For initial cold start-up with solid flat tappet cams and cast iron heads reduce the lash .002-.003"; with aluminum heads reduce them .007-.008". Recheck lash with the engine hot (not warm...Hot!). If necessary, correct the cold lash to give you the proper hot lash setting. On a new camshaft break-in always recheck the lash after the engine is broken in. Follow the enclosed valve adjustment procedure.



Call if you have any questions or problems
 Hughes Engines Inc.
 Phone (309) 745-9558 Fax (309) 296-9990

Illustration #1

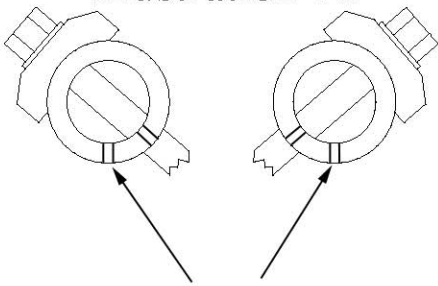

Oil holes as viewed from front of engine. The oil holes may be in line with the hold down bolt or offset. If offset, put them on the bottom.

You may need shims in these locations to align the rollers over the valve tips.

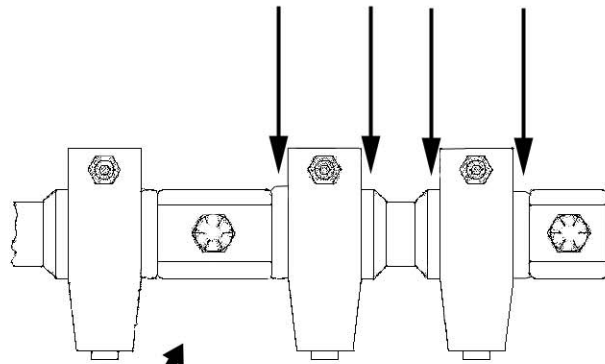

Illustration #2

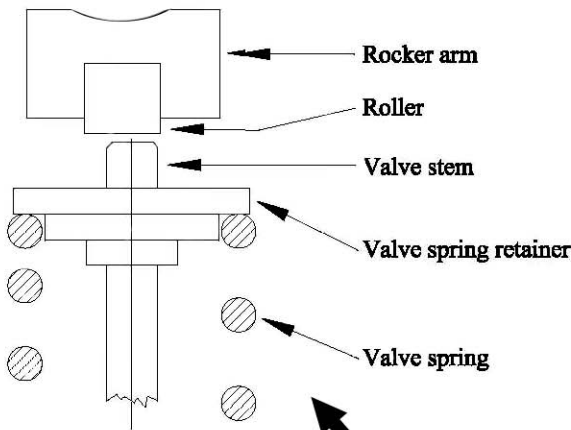
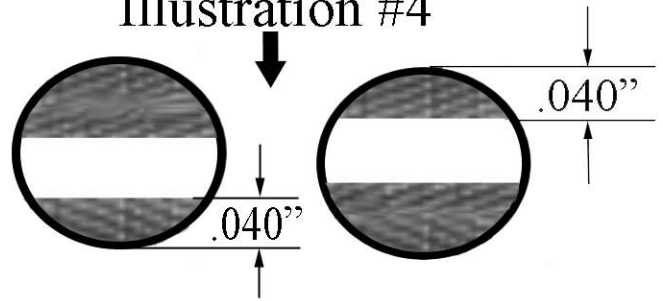

Illustration #3

In some applications it may be necessary to move the roller off-center on the valve tip. This is acceptable as long as the edge of the roller is over the edge of the valve tip, and the rocker doesn't hit the retainer. Centering is not mandatory.

Illustration #4



It is desirable to have the roller tip wipe pattern centered. This is not always possible on a Mopar so just get it as close as possible. The wipe area should be no closer than .040" from either edge of the valve tip.

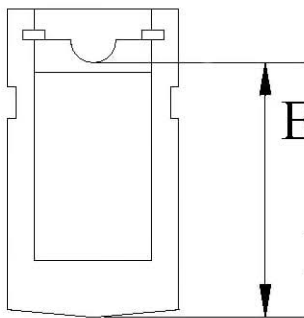

Effective Lifter Height

Measure from the bottom of the pushrod cup to the bottom of the lifter. Hydraulic lifters are taller than solids. Rollers are taller than flat tappets.

Illustration #5

Please call with any questions.

(309) 745-9558

information@Hughesengines.com



Valve adjustment on Mopar V8's

1. Position the piston in the #1 cylinder at TDC on the compression stroke (firing) using the TDC mark on the damper and the distributor rotor (it should be near the #1 cylinder terminal on the distributor cap).
2. Read the second column of the chart for the intake valves to adjust and the third column for the exhaust valve to adjust.
3. Rotate the crankshaft 90 degrees in the clockwise direction (when viewed from the front of the engine, at the damper). This will bring the #8 piston to TDC. Check the next line of the chart to find the valves to adjust.
4. Rotate the crankshaft another 90 degrees to adjust the next set of valves.
5. Repeat the process for the remaining cylinders.

Column #1	Column #2	Column #3
Position this piston at TDC	Adjust the INTAKE valve on this cylinder	Adjust the EXHAUST valve on this cylinder
1	2	8
8	1	4
4	8	3
3	4	6
6	3	5
5	6	7
7	5	2
2	7	1

